

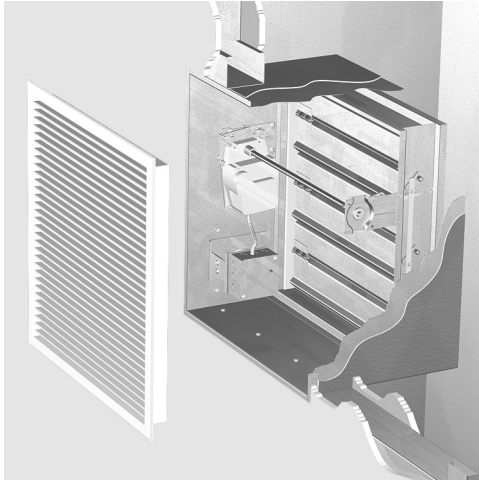

1½ Hour Combination Fire Smoke or Curtain Fire Dampers
Out of Wall or Out of Floor
Vertical or Horizontal Mount

Installation, Operation, and Maintenance Instructions



OFSD-XXX, ODFD-XXX, OFD-XXX, and OSSFD-XXX series dampers are intended for installation in accordance with combination fire smoke dampers requirements established by:

- NFPA National Fire Protection Association**
NFPA Standards 80, 90A, 92A, 92B, 101, & 105
- IBC International Building Codes**
- BOCA National Building Codes**
- ICBO Uniform Building Codes**
- SBCCI Standard Building Codes**
- New York City (MEA listing # 260-91-M)**
- California State Fire Marshal**
Listing #3225-0981:103 & 3230-0981:104

“UL Classified (see complete marking on product)”
“UL Classified to Canadian safety standards (see complete marking on product)”
UL Standard 555 & 555S (Classification R13317)

Receiving and Handling

Upon receiving dampers, check for both obvious and hidden damage. If damage is found, record all necessary information on the bill of lading and file a claim with the final carrier. Check to be sure that all parts of the shipment, including accessories, are accounted for.

Dampers must be kept dry and clean. Indoor storage and protection from dirt, dust and the weather is highly recommended. Do not store at temperatures in excess of 100°F (38°C).

Warranty

Greenheck warrants this equipment to be free from defects in material and workmanship for a period of one year from the purchase date. Any units or parts which prove to be defective during the warranty period will be repaired or replaced at our option. Greenheck shall not be liable for damages resulting from misapplication or misuse of its products. Greenheck will not be responsible for any installation or removal costs. Greenheck will not be responsible for any service work or backcharges without prior written authorization.

Electrical Guidelines

All wiring shall be done in accordance with the National Electrical Code ANSI/NFPA-70 latest edition, any local codes that may apply, and wiring diagrams developed in compliance with the job or project design and specifications.

Safety Warning:

Improper installation, adjustment, alteration, service or maintenance can cause property damage, injury or death. Read the installation, operating, and maintenance instructions thoroughly before installing or servicing this equipment.

Safety Caution!

Electrical input may be needed for this equipment. This work should be performed by a qualified electrician. Verify power before wiring actuator. Greenheck is not responsible for any damage to, or failure of the unit caused by incorrect field wiring. To avoid causing death or serious bodily harm to building occupants, follow all instructions carefully. Dampers must close completely to preserve the integrity of the fire smoke separation.

Due to continuing research, Greenheck reserves the right to change specifications without notice.

This manual is the property of the owner, and is required for future maintenance. Please leave it with the owner when the job is complete.

Table of Contents

Pre-Installation Guidelines.....	2
Installation	2-6
• Clearances Requirements	3
• Duct to Sleeve Connections.....	3
• Securing the Damper/Sleeve Assembly to Wall and Floor Openings	4
• Actuator Connections.....	4
• Recommended Preparation of Openings in Wood and Metal Stud Walls	5
• Breakaway Connections	5
Maintenance	8
Troubleshooting.....	8

Pre-Installation Guidelines

The basic intent of a proper installation is to secure the fire or fire smoke damper in, not to, the opening in such a manner as to prevent distortion and disruption of damper operation. This is accomplished by allowing the fire or fire smoke damper in rated separation openings to expand and for the connecting duct to separate in the event of the collapse of the hanging system. The following items will aid in completing the damper installation in a timely and effective manner.

- 1) Check the schedules for proper damper locations within the building. Visually inspect the damper for damage and verify that the Reusable Resettable Link (RRL) is in place or has not activated. Never install a fire damper without the proper UL approved RRL in place. (RRL is standard control option. These electric links have a button for resetting.) If damper is furnished with fusible link, visually inspect the link to verify its not missing or broken. Replace link as necessary.
- 2) Lift or handle damper using sleeve or frame. Do not lift damper using blades or actuators.
- 3) Damper has label on outside of sleeve indicating a 'No Screw' area. Do not install screws into this area as screws may interfere with unexposed blade linkage and prevent damper blades from opening and/or closing.
- 4) Damper has label indicating position of damper and sleeve assembly in the wall. Install accordingly to comply with manufacturer's appropriate UL Classification file number.
- 5) Damper must be installed into duct or opening square and free of twist or other misalignment. Damper must not be squeezed or stretched into duct or opening. Out of square, racked, twisted or misaligned installations can cause excessive leakage and/or torque requirements to exceed damper/actuator design.
- 6) Damper and actuator must be kept clean and protected from dirt, dust and other foreign materials prior to and after installation. Examples of such foreign materials include but are not limited to:
 - a) Mortar dust
 - b) Drywall dust
 - c) Firesafing materials
 - d) Wall texture
 - e) Paint overspray
- 7) Damper should be sufficiently covered as to prevent overspray if wall texturing or spray painting will be performed within 5 feet of the damper. Excessive dirt or foreign material deposits on damper can cause excessive leakage and/or torque requirements to exceed damper/actuator design.
- 8) Caulking is not necessary, nor is it allowed, between the damper sleeve and the wall or floor opening (annular space). However, caulking may be applied to the retaining angles.
- 9) ACCESS: Suitable access (such that RRL's and actuators can be maintained, etc.) must be provided for damper inspection and servicing. Where it is not possible to achieve sufficient size access, it will be necessary to install a removable section of duct. (Refer to NFPA 90A).
- 10) The Code Authority Having Jurisdiction (AHJ) must evaluate and provide approval of final installation where variations to these instructions are necessary.

Installation - Failure to follow these instructions will void all warranties.

These instructions apply to 1½ hour rated combination fire smoke dampers and curtain fire dampers mounted in masonry, block, wood or metal stud walls, or concrete floors. Specific requirements in these instructions are mandatory. These instructions meet the requirements of UL555. Installation shall comply with the requirements of NFPA 90A (Installation of Air Conditioning and Ventilating Systems) and UL listing R13317.

1. DAMPER IS INSTALLED OUTSIDE OF WALL PLANE OFSD-XXX

Figure 1 shows two approved installations for combination fire smoke dampers: 1) "Through the grille access" and 2) installation in continuing duct. To provide "through the grille" access to the damper actuator, the damper is located toward the back of the sleeve and the actuator is installed between the damper and grille. Actuator and damper can be accessed and serviced by removing the grille. To provide access to the damper actuator for continuing ductwork, refer to the requirements of NFPA 90A.

ODFD-XXX, OFD-XXX, and OSSFD-XXX: Figure 1 shows two installations that are also approved for curtain fire dampers. For access to inspect the damper and fusible link, refer to the requirements of NFPA 90A.

2. CLEARANCE REQUIREMENTS

There is no minimum clearance requirement between the wall/floor opening and the sleeve exterior (with thermal blanket attached). However, to facilitate installation, clearances between the wall/floor opening and the damper sleeve are recommended. although there is no maximum allowable clearance, the minimum overlap requirements between the wall/floor and the flange/retaining angle must be met. On grill mount installations the flange must overlap the wall/floor by 1/2 in. (13mm). On continuous duct installations, the retaining angles must overlap the wall/floor by 1 in. (25mm). Because no clearances are required between the wall/floor opening and the sleeve, dampers may not be installed in the plane of the wall using this installation method.

3. DUCT TO SLEEVE CONNECTIONS

Dampers are supplied with actuators (on applicable models) and sleeves from the factory and can be installed without the need for additional field installed sleeves.

Sleeve gauges of 20-14 (.9mm - 2mm) are to be used. UL Standard 555 requires all ducts to terminate at fire damper sleeves. Sleeve thickness must not be less than the gauge of the connecting duct.

Duct to sleeve breakaway connections must be of the type described on page 5. Factory furnished round duct collars on type R and CR dampers are also considered to be breakaway connections and may be used.

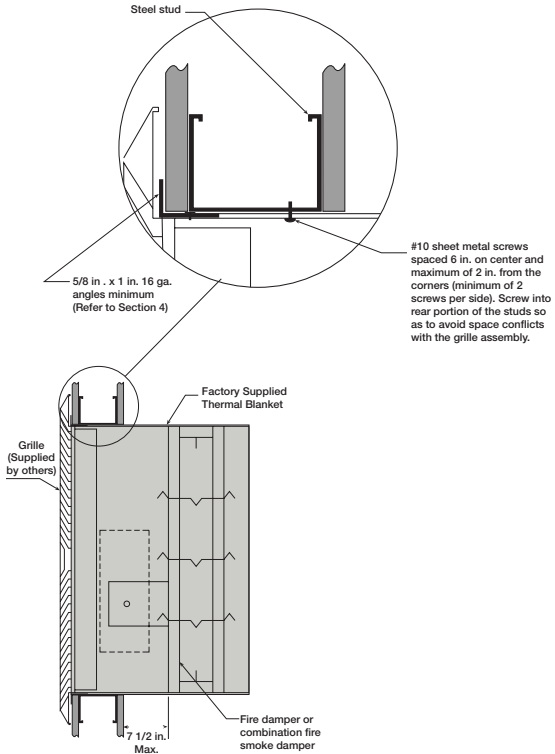

"Duct Terminates" Metal Stud

Note: Both installations may be vertical or horizontal.

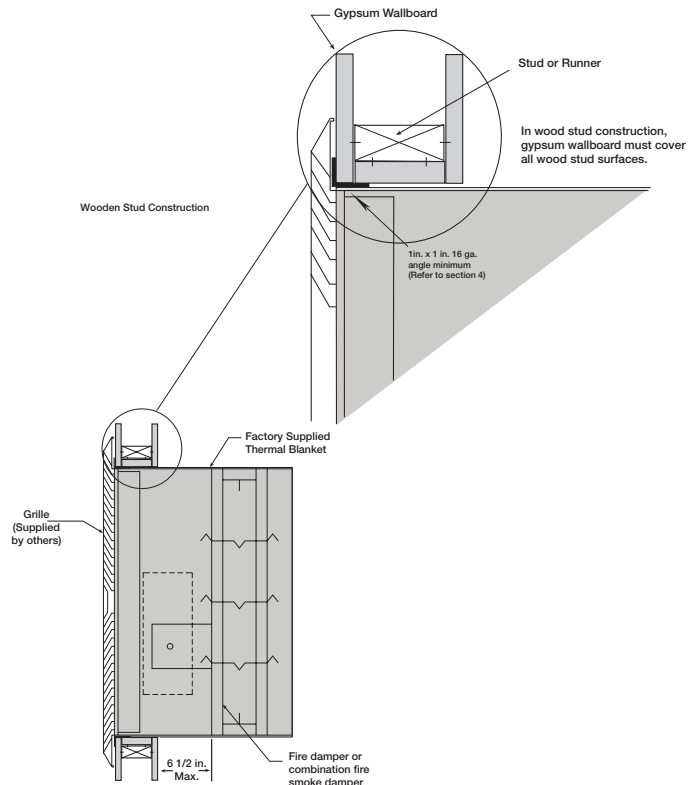

"Duct Terminates" Wood Stud

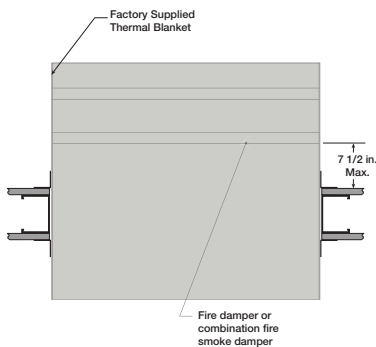

"Duct Continues"

Figure 1: Installation configurations for 'Out of Wall' curtain fire dampers and combination fire smoke dampers.

4. SECURING THE DAMPER/SLEEVE ASSEMBLY TO WALL OPENINGS.

Damper/sleeve assemblies must be installed in wall openings using flanges and sheet metal screws as illustrated and described below.

- Flange on front (grille end) of sleeve must be a minimum of 16 gauge (1.5mm) steel and have a 5/8 in. (16mm) minimum flange leg (refer to **Figure 2**). Using #10 (19mm) sheet metal screws, screw from inside of sleeve through the rear portion of the studs (as shown in **Figure 1**). Space screws a maximum of 6 in. (152mm) on center and a maximum of 2 in. (51mm) from the corners (minimum of 2 screws per side). No retaining angles are required on the side of wall opposite from the grille.
- Retaining angles on continuing duct must be a minimum of 1 1/2 in. x 1 1/2 in. (38mm x 38mm) 16 gauge (1.5mm) steel (refer to **Figure 3**). Screwing sleeve to steel studs is not required.
- Retaining angles must be attached to the sleeve using one or more of the following methods of attachment:
 - Tack or spot welds
 - #10 (19mm) sheet metal screws
 - 1/4 in. (6mm) bolts and nuts
 - 3/16 in. (4.7mm) steel pop rivets

Attachments must be spaced a minimum of 6 in. (152mm) on center and a maximum of 2 in. (51mm) from corners. The angles must be attached to all 4 sides of the sleeve. A minimum of two attachments are required on each side, top and bottom. The angles need not be attached to each other at the **corners**.

CAUTION! Do not tear the thermal blanket during installation.

Dampers are tested for correct operation and are square and straight before shipment from the factory. Dampers must be installed square and straight and must not be twisted or racked. Failure to install the damper square and straight may prevent the damper blades from operating open and closed.

5. ACTUATOR CONNECTIONS

Electrical and/or pneumatic connections to damper actuators should be made in accordance with wiring and piping diagrams developed in compliance with applicable codes, ordinances and regulations (see **Electrical Guidelines**).

6 Recommended Preparation of Openings in Wood and Metal Stud Walls

- Frame wall openings as shown (see **Figure 4**)
- Double vertical studs are not required for openings 36 in. x 36 in. (914mm x 914mm) or smaller.
- Gypsum wall board must be fastened 12 in. (305mm) on center to all stud and runner flanges surrounding opening(see **Figure 4**).
- All construction and fasteners must meet the requirements of the appropriate wall design (See UL Fire Resistance Directory) and/or local codes.

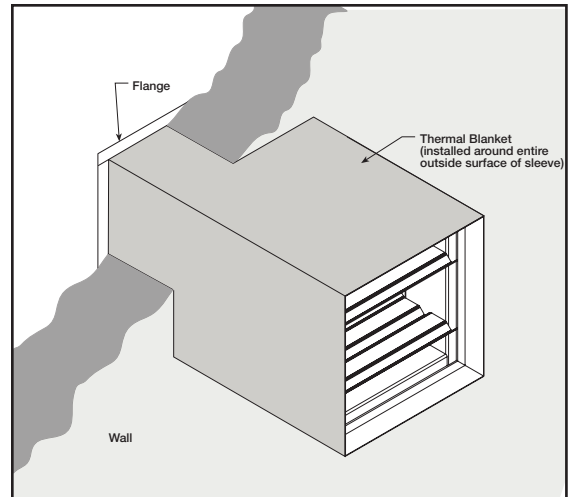

Figure 2: Sleeved damper with Thermal Blanket (duct termination).

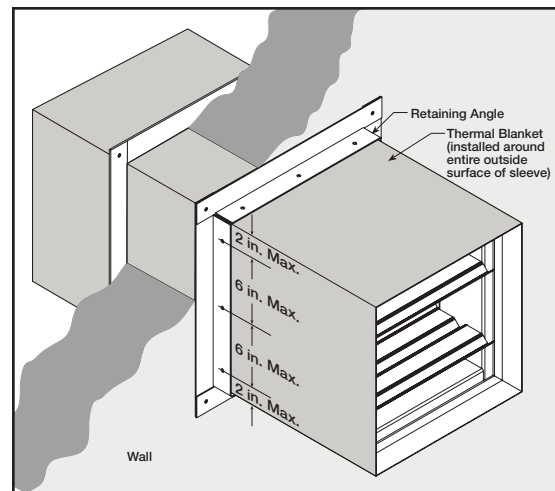

Figure 3: Sleeved damper with Thermal Blanket (duct continuation).

Note: Thermal blanket is riveted to the damper sleeve and the seam is taped with acrylic adhesive tape, FSK facing tape 152 5CWnt, manufactured by Venture Tape Company.

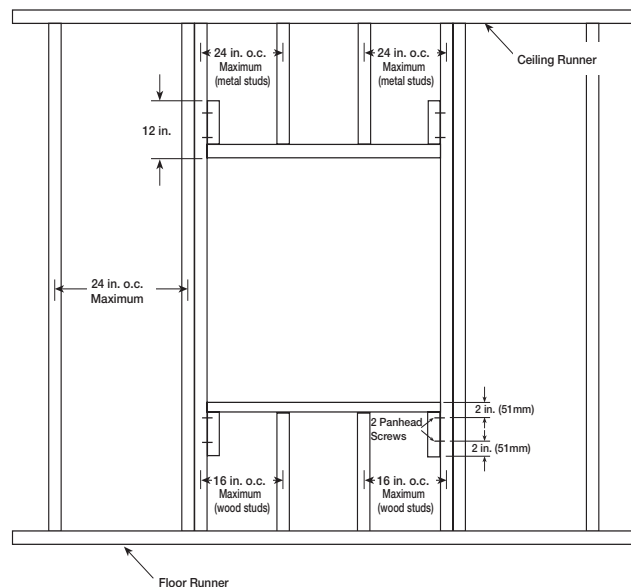

Figure 4

Breakaway Connections

Traditional Breakaway Style Transverse Joints

Transverse joints illustrated at right have always been approved as breakaway connections. SMACNA testing has also approved the following variations as breakaway connections.

- The breakaway connections shown (Fig. 6) can be applied with maximum of two #10 (19mm) sheet metal screws on each side and on the bottom located in the center of the slip pocket and penetrating both sides of the slip pocket.
- Transverse joints illustrated can be applied as top and bottom joints with Drive Slip - side joints in duct heights up to 20 inches (508mm) See Fig. 5.



Fig. 5

Round and Oval Duct Breakaway Connections

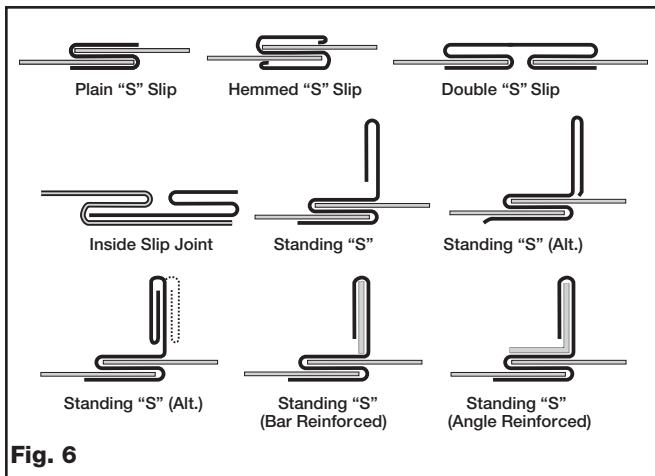

Fig. 6

Round or flat oval ducts connected to Type R or O damper collars shall be attached with #10 (19mm) sheet metal screws as follows:

- Ducts to 22 in. (558mm) wide (or dia.) and smaller shall have three screws.
- Ducts larger than 22 in. (558mm) wide (or dia.) up to and including 36 in. (914mm) wide (or dia.) shall have five screws.

NOTE: All breakaway connections described may have duct sealant applied, PA2084T duct sealant adhesive manufactured by Precision, DP1010 water base duct sealant manufactured by Design Polymetrics, or Grey Pookie in accordance with SMACNA recommendations.

Manufactured Flanged System Breakaway Connections

Flanged connection systems manufactured by Ductmate, Ward, and Nexus are approved as breakaway connections when installed as illustrated (Fig. 7).

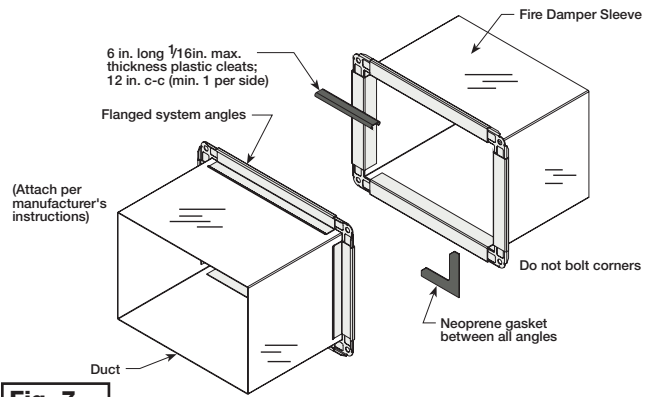
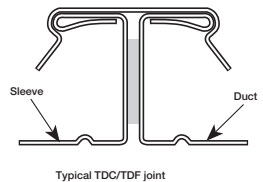

Fig. 7

Proprietary Flange System Breakaway Connections (TDC by Lockformer, TDF by Engle)

TDC and TDF systems are approved as breakaway connections when installed as described in the TDC or TDF addendum to the SMACNA Duct Construction Standards except the corners may not be bolted. Standard 6 in. (152mm) metal clip may be used with spacing as shown in Figure 8. 3/8 in. (9.5mm) metal bolts and nuts may be used to fasten together corner pieces (see Fig. 9).



Typical TDC/TDF joint

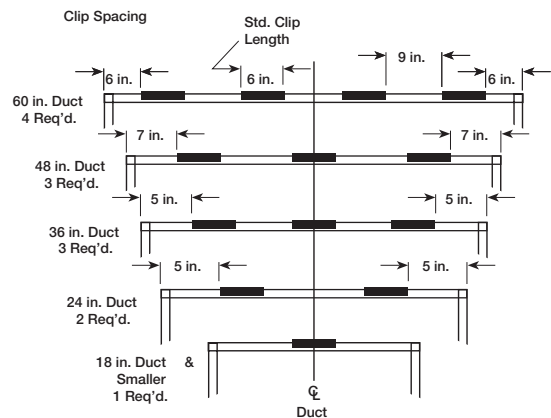

Figure 8: Detail of proprietary flanged system breakaway connections.

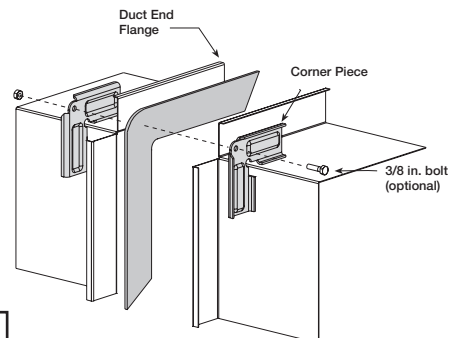

Fig. 9

Damper Maintenance

Dampers do not typically require maintenance as long as they are kept dry and clean. If cleaning is necessary, use mild detergents or solvents. If lubrication is desired for components such as axle bearings, jackshaft bearings and jamb seals, do not use oil-based lubricants or any other lubricants that attract contaminants such as dust.

Dampers and their actuator(s) must be maintained, cycled, and tested a minimum in accordance with:

- The latest editions of NFPA 80, 90A, 92A, 92B, 101, 105, UL864, AMCA 503-03 and local codes.
- Actuator manufacturer recommendations.

Damper Troubleshooting

The following is a possible cause and correction list for common concerns with the dampers.

Symptom	Possible Cause	Corrective Action
Damper does not fully open and/or close	Frame is 'racked' causing blades to bind on jamb seals	Adjust frame such that it is square and plumb
	Actuator linkage loose	Close damper, disconnect power, adjust and tighten linkage
	Defective motor	Replace
	Screws in damper linkage	Damper installed too far into wall. Move out to line as designated on damper label
	Contaminants on damper	Clean with a non-oil based solvent (see Damper Maintenance)
RRL or TOR sensor tripped	Heat	Push reset button located on backside of RRL or TOR
Damper does not operate	No power supplied to the actuator	Add power supply

